



# LP210\*210-M-66-MH

Rated Power 650-670W



Monofacial

## Energie naší hvězdy

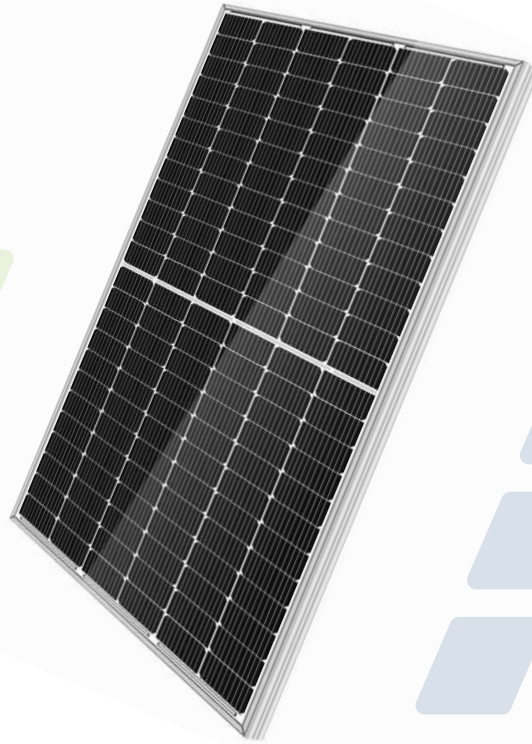

### MBB Cell

New circuit design, lower internal current, lower internal resistance loss.



### Low Light Features

Higher performance under low light environment.



### Higher Output Power

Module adopts 144 pcs of 182\*182mm half cells, the maximum power can reach 560W.



### PID Protection

Ensure the attenuation probability caused by PID phenomenon is minimized.



### Harsh Environmental Adaptability

Strict salt spray and ammonia corrosion test by TUV Nord.



### Load Capacity

Mechanical load tests including wind load 2400 Pa and snow load 5400 Pa done by TUV Nord.

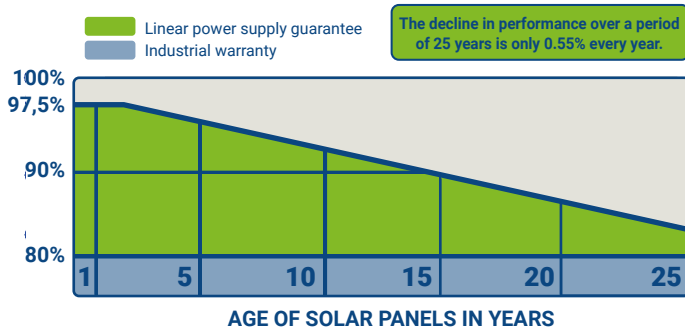

\*J-PEC Product



IEC 61215-2: 2016  
IEC 61730-2: 2016

7ma s.r.o.

Tiskárenská 440  
672 01 Moravský Krumlov

INSTALACE A INFORMACE

☎ 771 111 122  
✉ info@7ma.cz

OBCHOD A OBJEDNÁVKY

☎ 771 111 115  
✉ obchod@7ma.cz

WEB a E-SHOP

WWW.7ma.CZ

## MECHANICAL DIAGRAMS

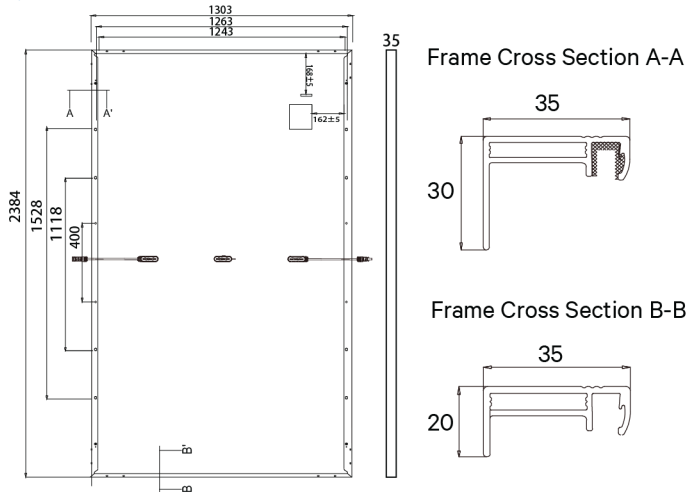

## SPECIFICATIONS

Weight	34kg
Dimensions	2384mm*1303mm*35mm
Cell Dimensions	210*210mm
Cell Amount	66*2 pcs
Maximum System Voltage	1500V
Junction Box	IP68
Frame	Aluminum Alloy
Cable	4mm <sup>2</sup> , N 320mm/P 320mm or customized length
Connector	MC4 compatible
Application Level	Class A

## ELECTRICAL PARAMETERS AT STC

Power	650W	655W	660W	665W	670W
Open Circuit Voltage	45.58V	45.78V	45.98V	46.18V	46.38V
Short Circuit Current	18.16A	18.21A	18.26A	18.31A	18.36A
Maximum Power Voltage	37.61V	37.81V	38.01V	38.21V	38.41V
Maximum Power Current	17.28A	17.32A	17.36A	17.40A	17.44A
Module Efficiency	20.92%	21.09%	21.25%	21.41%	21.57%

\* Under Standard Test Conditions (STC) of irradiance of 1000 W/m<sup>2</sup>, spectrum AM 1.5 and cell temperature of 25°C.

## ELECTRICAL PARAMETERS AT NMOT

Power	491W	495W	499W	503W	507W
Open Circuit Voltage	42.30V	42.48V	42.67V	42.86V	43.04V
Short Circuit Current	14.89A	14.93A	14.97A	15.01A	15.06A
Maximum Power Voltage	34.86V	35.05V	35.24V	35.42V	35.61V
Maximum Power Current	14.09A	14.13A	14.16A	14.19A	14.23A
Module Efficiency	15.82%	15.94%	16.06%	16.18%	16.32%

\* Under Nominal Module Operating Temperature (NMOT), irradiance of 800 W/m<sup>2</sup>, spectrum AM 1.5, ambient temperature 20°C, wind speed 1 m/s.

## TEMPERATURE CHARACTERISTICS

NMOT	41±3°C	Temp Coefficient of ISC	+0.04%/°C
Temp Coefficient of VOC	-0.25%/°C	Temp Coefficient of Pmax	-0.34%/°C

## PACKING CONFIGURATION

Modules/Pallet	32 Pieces	Modules/40'Container	576 Pieces
Packing Description	18 Pallets, Total=32x18=576 Pieces		

## CHARACTERISTICS

LP210\*210-M-66-MH-660W

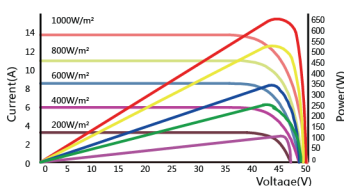

LP210\*210-M-66-MH-660W

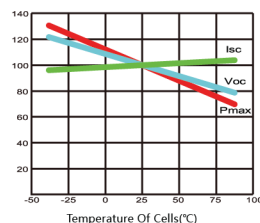

## MAXIMUM RATING

Output Tolerance	0~+5W
Operating Temperature	-40°C~+85°C
Wind Load/Snow Load	2400pa/5400pa
Fuse Current	30A

**15** YEARS Quality Warranty

**25** YEARS Power Warranty